





Certificate for the UL Mark – Performance of Cladding and Cladding Support Systems

Section 1 – Certificate Details:

Customer Name:	RJ Facade Systems Ltd	Certification Body:	UL International (UK) Ltd
Customer Address:	Inchmuir Road Bathgate West Lothian EH48 2EP	Certification Body Address:	Halesfield 2 Telford Shropshire TF7 4QH
UL Scheme:	Performance of Rainscreen Cladding Support Systems BSFO Issue 2	Certificate Number:	R40530-1 Rev 3
Date of Certification Commencement:	9th October 2019	Date of Certification Expiry:	8th October 2025
Certificate Compiled by:	Mark Swanborough Certification Leader	Certificate Approved by:	Michael Wass Engineering Manager
Signed:		Signed:	

Section 2 – Products covered by this Certificate:



System Name	System Type
RJ Facade Systems	Rainscreen Cladding Support system
<p>This Certification Covers</p> <ul style="list-style-type: none"> - A detailed overview of the certified products - Technical Specifications of the products - An initial assessment of the certified company's factory production control systems. - Design considerations - A review of the products documentation to help demonstrate compliance with the applicable requirements of the UL Scheme. - An assessment of the certified products contribution to any key requirements of the building regulations. - An overview of the certified companies product installation requirements and procedures. - An overview of all supporting test documentation used for the product evaluation. - Ongoing surveillance of the certified company's factory production control system and procedures. - The conditions under which this product certification is valid. 	



General Description

RJ Facade Systems supply into the UK market, Facade Support Systems for all the façade materials used in ventilated facades designed and manufactured in partnership with other manufacturers in the UK.

This UL certification covers the range a brackets and components listed below. The certified companies head office is situated in Bathgate, West Lothian, with the Facades Division based in Guildford, Surrey. The aluminium EVT brackets and components are manufactured and fabricated in the UK at UL audited manufacturing sites.

All products are dispatched/transported to the RJ UK warehouse in Bathgate prior to distribution to the client. The certificate incorporates the UK distribution of RJ Facade Systems Ltd cladding support systems with their UL approved supply chain.

Summary of Certified Products

EVT Helping Hand Wall Brackets

- EVT II - Aluminium FPH & SPH, for Concrete and SFS Standard L Brackets
- EVT - Aluminium FPH & SPH, for Concrete and SFS Standard L Brackets
- EVT II - Stainless Custom FPH & SPH, for Concrete and SFS Standard L Brackets
- EVT II U Brackets - Aluminium FPH, SPH, & Combi, slots for Concrete and SFS Performance Brackets
- EVT II U Brackets - Stainless FPH, SPH, & Combi, slots for Concrete and SFS Performance Brackets
- EVT II Horizontal Adaptor - Aluminium FPH & SPH

EVT Vertical and Horizontal Rail Types

- L Profiles for L brackets
- T Profiles for L brackets
- Floorspan profiles for U brackets
- Structural Tophats & C Channels for spanning SFS
- Tophat & Z Profiles for façade panels
- System Profiles Bravo W, Vario C20

Horizontal Carrier Rail Systems for Forte L, Forte, Kerf, & Vario C20

- System Components - EVT Light - Horizontal system, d = 30mm, t=2.3mm, w = 60mm
- System Components - EVT Forte - Horizontal system, d = 32mm, t=3.8mm, w = 60mm
- System Components - Kerf - Horizontal system, d = 34mm, t=3-4mm
- System Components - Bravo H - Horizontal system, d = 39mm, t=1.8mm

Suitable fixing types – not UL certified and subject to project approval

- Concrete Screws for fixing to concrete and blockwork - ETA approved for cracked and non-cracked concrete applications
- Resin systems for fixing to concrete and blockwork - ETA approved for cracked and non-cracked concrete applications
- Through bolt for fixing to concrete only - ETA approved for cracked and non-cracked concrete applications
- Frame fixing for fixing to concrete and blockwork - ETA approved
- For fixing vertical profiles to wall brackets & horizontal rail to vertical rail
- For fixing wall brackets to tophats and C-channels
- For fixing components to light steel sections 1.2 to 3.0mm steel
- For fixing components to hot rolled steel sections 4.0 to 12.0mm steel
- For fixing components for soffit frameworks or cladding brackets to timber
- For fixing wood parts to aluminium substructure

EVT Facade Support Systems for typical façade materials used in ventilated



Vario F, Rivet fix



Vario G, structural bond fix

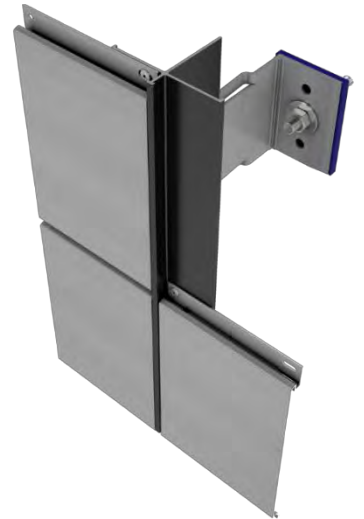

Vario L, Plank System



Vario C20, Ceramic Panel Systems



Bravo H, Panel System



Bravo W, Cassette Panel

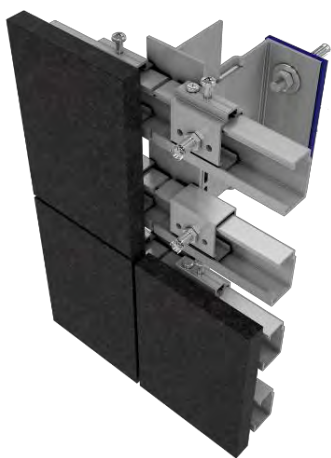

Forte L, Secret fix Eternit to 40kg Stone

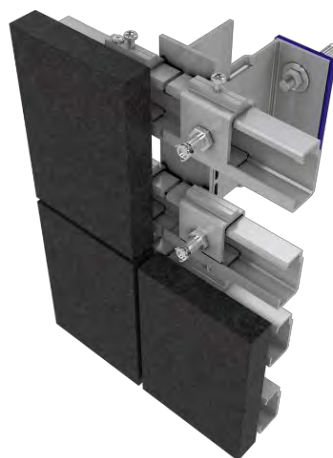

Forte, Secret fix up to 60kg Stone

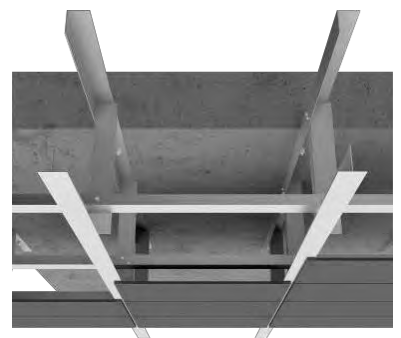

Soffit design

Copyright © 2020 UL International (UK) Ltd, Unit 1-3 Horizon, Kingsland Business Park, Wade Road, Basingstoke, Hampshire RG24 8AH, UK authorizes the above named company to reproduce this Certificate only for purposes as described in the Service Terms.

Section 4 – Certified Product Specifications

EVT II - Aluminium FPH & SPH, for Concrete and SFS Standard L Brackets

Code	Description	Design Resistance (kN)	
		Vertical	Horizontal
130170	EVT II L Bracket Thermal AL - 80 x 40mm	5.06	2.75
130171	EVT II L Bracket Thermal AL - 80 x 60mm	3.53	2.75
130172	EVT II L Bracket Thermal AL - 80 x 80mm	1.87	1.95
130173	EVT II L Bracket Thermal AL - 80 x 100mm	1.69	2.04
130174	EVT II L Bracket Thermal AL - 80 x 120mm	1.28	2.09
130175	EVT II L Bracket Thermal AL - 80 x 140mm	1.06	2.04
130176	EVT II L Bracket Thermal AL - 80 x 160mm	0.96	1.95
130177	EVT II L Bracket Thermal AL - 80 x 180mm	1.18	2.00
130178	EVT II L Bracket Thermal AL - 80 x 200mm	1.07	2.00
130179	EVT II L Bracket Thermal AL - 80 x 220mm	0.85	2.00
130180	EVT II L Bracket Thermal AL - 80 x 240mm	0.88	1.95
130181	EVT II L Bracket Thermal AL - 80 x 260mm	0.81	2.00
130182	EVT II L Bracket Thermal AL - 80 x 280mm	0.66	2.01
130183	EVT II L Bracket Thermal AL - 80 x 300mm	0.68	1.94
130184	EVT II L Bracket Thermal AL - 80 x 320mm	0.64	1.94
130185	EVT II L Bracket Thermal AL - 160 x 40mm	10.12	6.00
130186	EVT II L Bracket Thermal AL - 160 x 60mm	9.57	4.54
130187	EVT II L Bracket Thermal AL - 160 x 80mm	6.70	3.77
130188	EVT II L Bracket Thermal AL - 160 x 100mm	4.91	3.77
130189	EVT II L Bracket Thermal AL - 160 x 120mm	4.12	3.77
130190	EVT II L Bracket Thermal AL - 160 x 140mm	3.46	3.77
130191	EVT II L Bracket Thermal AL - 160 x 160mm	3.00	3.77
130192	EVT II L Bracket Thermal AL - 160 x 180mm	2.75	3.81
130193	EVT II L Bracket Thermal AL - 160 x 200mm	2.59	3.81
130194	EVT II L Bracket Thermal AL - 160 x 220mm	2.39	4.02
130195	EVT II L Bracket Thermal AL - 160 x 240mm	2.06	3.81
130196	EVT II L Bracket Thermal AL - 160 x 260mm	1.99	3.81
130197	EVT II L Bracket Thermal AL - 160 x 280mm	1.75	3.81
130198	EVT II L Bracket Thermal AL - 160 x 300mm	1.62	3.81
130199	EVT II L Bracket Thermal AL - 160 x 320mm	1.42	3.81
Note above references include Thermal Pad, also available without Thermal Pad			
130530	EVT II Thermal pad 80 x 42mm		
130531	EVT II Thermal pad 160 x 42mm		

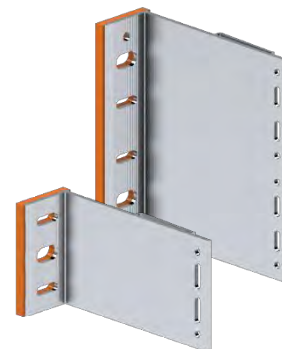

EVT II Horizontal Adaptor - aluminium

Code	Description	Design Resistance (kN)	
		Vertical	Horizontal
522161	EVT II Horizontal Adaptor - 85 x 80 x 3mm	1.92	2.80
522161 +	EVT II L Bracket Thermal AL - 80 x 40mm + Adaptor	1.92	2.75
522161 +	EVT II L Bracket Thermal AL - 80 x 60mm + Adaptor	1.92	2.75
522161 +	EVT II L Bracket Thermal AL - 80 x 80mm + Adaptor	1.87	1.95
522161 +	EVT II L Bracket Thermal AL - 80 x 100mm + Adaptor	1.69	2.04
522161 +	EVT II L Bracket Thermal AL - 80 x 120mm + Adaptor	1.28	2.09
522161 +	EVT II L Bracket Thermal AL - 80 x 140mm + Adaptor	1.06	2.04
522161 +	EVT II L Bracket Thermal AL - 80 x 160mm + Adaptor	0.96	1.95
522161 +	EVT II L Bracket Thermal AL - 80 x 180mm + Adaptor	1.18	2.00
522161 +	EVT II L Bracket Thermal AL - 80 x 200mm + Adaptor	1.07	2.00
522161 +	EVT II L Bracket Thermal AL - 80 x 220mm + Adaptor	0.85	2.00
522161 +	EVT II L Bracket Thermal AL - 80 x 240mm + Adaptor	0.88	1.95
522161 +	EVT II L Bracket Thermal AL - 80 x 260mm + Adaptor	0.81	2.00
522161 +	EVT II L Bracket Thermal AL - 80 x 280mm + Adaptor	0.66	2.01
522161 +	EVT II L Bracket Thermal AL - 80 x 300mm + Adaptor	0.68	1.94
522161 +	EVT II L Bracket Thermal AL - 80 x 320mm + Adaptor	0.64	1.94

Note to use code 522161 with relevant EVT II bracket code.



EVT - Aluminium FPH & SPH, for Concrete and SFS Standard L Brackets

Code	Description	Design Resistance (kN)	
		Vertical	Horizontal
515872	EVT L Bracket (F/SPH) AL - 80 x 40mm	5.53	1.95
516371	EVT L Bracket (F/SPH) AL - 80 x 75mm	2.74	1.95
516376	EVT L Bracket (F/SPH) AL - 90 x 100mm	1.91	1.95
516380	EVT L Bracket (F/SPH) AL - 90 x 125mm	1.48	1.95
516378	EVT L Bracket (F/SPH) AL - 90 x 150mm	1.20	1.95
515870	EVT L Bracket (F/SPH) AL - 90 x 180mm	0.98	1.95
516382	EVT L Bracket (F/SPH) AL - 90 x 210mm	0.91	1.95
517916	EVT L Bracket (F/SPH) AL - 90 x 240mm	0.72	1.95
522404	EVT L Bracket (F/SPH) AL - 90 x 270mm	0.63	1.95
517917	EVT Bracket SPH - 100/90 mm (Extension)		
515871	EVT L Bracket (F/SPH) AL - 160 x 40mm	12.56	4.46
516384	EVT L Bracket (F/SPH) AL - 160 x 75mm	7.50	4.46
516377	EVT L Bracket (F/SPH) AL - 160 x 100mm	5.30	4.47
516381	EVT L Bracket (F/SPH) AL - 160 x 125mm	4.07	4.45
516379	EVT L Bracket (F/SPH) AL - 160 x 150mm	3.31	4.46
515869	EVT L Bracket (F/SPH) AL - 160 x 180mm	2.71	4.50
516383	EVT L Bracket (F/SPH) AL - 160 x 210mm	2.32	4.36
517918	EVT L Bracket (F/SPH) AL - 160 x 240mm	1.98	4.46
522403	EVT L Bracket (F/SPH) AL - 160 x 270mm	1.74	4.46
517919	EVT Bracket FPH - 100/160 mm (Extension)		
534726	EVT Thermal pad 80 x 62mm (AL 40-75mm)		
535528	EVT Thermal pad 160 x 62mm (AL 40-75mm)		
130530	EVT Thermal pad 90 x 60mm		
535529	EVT Thermal pad 160 x 60mm		

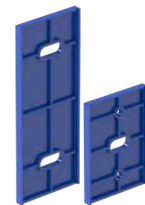

EVT II – 3mm Stainless FPH & SPH, (A2 & A4) for Concrete and SFS Standard L Brackets

Code	Description	Design Resistance (kN)	
		Vertical	Horizontal
300408	EVT II L Bracket A2 - 80 x 40mm	2.20	1.13
300409	EVT II L Bracket A2 - 80 x 60mm	1.33	1.13
300410	EVT II L Bracket A2 - 80 x 80mm	0.95	1.13
300411	EVT II L Bracket A2 - 80 x 100mm	0.74	1.13
300412	EVT II L Bracket A2 - 80 x 120mm	0.59	1.13
300414	EVT II L Bracket A2 - 80 x 140mm	0.51	1.13
300415	EVT II L Bracket A2 - 80 x 160mm	0.43	1.13
300416	EVT II L Bracket A2 - 80 x 180mm	0.40	1.13
300417	EVT II L Bracket A2 - 80 x 200mm	0.34	1.13
300418	EVT II L Bracket A2 - 80 x 220mm	0.30	1.13
300419	EVT II L Bracket A2 - 80 x 240mm	0.28	1.13
300421	EVT II L Bracket A2 - 80 x 260mm	0.32	1.13
300422	EVT II L Bracket A2 - 80 x 280mm	0.24	1.13
300423	EVT II L Bracket A2 - 80 x 300mm	0.22	1.13
300424	EVT II L Bracket A2 - 80 x 320mm	0.20	1.13
300427	EVT II L Bracket A2 - 160 x 40mm	7.55	2.73
300428	EVT II L Bracket A2 - 160 x 60mm	4.86	2.73
300429	EVT II L Bracket A2 - 160 x 80mm	3.48	2.73
300430	EVT II L Bracket A2 - 160 x 100mm	2.72	2.73
300431	EVT II L Bracket A2 - 160 x 120mm	2.23	2.73
300433	EVT II L Bracket A2 - 160 x 140mm	1.90	2.73
300434	EVT II L Bracket A2 - 160 x 160mm	1.65	2.73
300435	EVT II L Bracket A2 - 160 x 180mm	1.39	2.73
300436	EVT II L Bracket A2 - 160 x 200mm	1.30	2.73
300437	EVT II L Bracket A2 - 160 x 220mm	1.18	2.73
300438	EVT II L Bracket A2 - 160 x 240mm	1.07	2.73
300440	EVT II L Bracket A2 - 160 x 260mm	1.00	2.73
300441	EVT II L Bracket A2 - 160 x 280mm	0.91	2.73
300442	EVT II L Bracket A2 - 160 x 300mm	0.85	2.73
300443	EVT II L Bracket A2 - 160 x 320mm	0.79	2.73



Note EVT II stainless available in A2 & A4.

130530	EVT II Thermal pad 80 x 42mm
130531	EVT II Thermal pad 160 x 42mm

EVT II Soffit Hanger – 2mm & 3mm Aluminium, slots for Concrete

Code	Description	Design Resistance (kN)	
		Vertical	Horizontal
553336	EVT II L Soffit Bracket AL - 160 x 60 x 2mm	1.96	n/a
553337	EVT II L Soffit Bracket AL - 80 x 60 x 2mm	1.18	n/a
553338	EVT II L Soffit Bracket AL - 160 x 60mm x 3mm	3.61	n/a
553339	EVT II L Soffit Bracket AL - 80 x 60mm x 3mm	2.22	n/a



EVT II U Brackets – 4mm Aluminium FPH & SPH & Combi, slots for Concrete and SFS Performance Brackets

Code	Description	Design Resistance (kN)	
		Vertical	Horizontal
300495	EVT II U Bracket AL - 80 x 40mm	3.85	2.46
300496	EVT II U Bracket AL - 80 x 60mm	2.52	2.46
300497	EVT II U Bracket AL - 80 x 80mm	1.78	2.46
300498	EVT II U Bracket AL - 80 x 100mm	1.28	2.46
300499	EVT II U Bracket AL - 80 x 120mm	1.02	2.46
300500	EVT II U Bracket AL - 80 x 140mm	0.93	2.36
300501	EVT II U Bracket AL - 80 x 160mm	0.77	2.46
300502	EVT II U Bracket AL - 80 x 180mm	0.70	2.46
300503	EVT II U Bracket AL - 80 x 200mm	0.64	2.46
300504	EVT II U Bracket AL - 80 x 220mm	0.53	2.25
300505	EVT II U Bracket AL - 80 x 240mm	0.49	2.25
300506	EVT II U Bracket AL - 80 x 260mm	0.47	2.38
300507	EVT II U Bracket AL - 80 x 280mm	0.41	2.38
300508	EVT II U Bracket AL - 80 x 300mm	0.40	2.35
300509	EVT II U Bracket AL - 80 x 320mm	0.38	2.46
300478	EVT II U Bracket AL - 160 x 40mm	11.81	4.41
300479	EVT II U Bracket AL - 160 x 60mm	7.87	4.41
300480	EVT II U Bracket AL - 160 x 80mm	5.70	4.41
300481	EVT II U Bracket AL - 160 x 100mm	4.56	4.41
300482	EVT II U Bracket AL - 160 x 120mm	3.72	4.41
300483	EVT II U Bracket AL - 160 x 140mm	3.16	4.41
300484	EVT II U Bracket AL - 160 x 160mm	2.73	4.41
300485	EVT II U Bracket AL - 160 x 180mm	2.35	4.23
300486	EVT II U Bracket AL - 160 x 200mm	2.16	4.37
300487	EVT II U Bracket AL - 160 x 220mm	1.97	4.37
300488	EVT II U Bracket AL - 160 x 240mm	1.75	4.37
300489	EVT II U Bracket AL - 160 x 260mm	1.55	4.37
300490	EVT II U Bracket AL - 160 x 280mm	1.42	4.37
300491	EVT II U Bracket AL - 160 x 300mm	1.32	4.37
300492	EVT II U Bracket AL - 160 x 320mm	1.29	4.37
300512	EVT II U Bracket Combi AL - 160 x 40mm	13.22	6.97
300513	EVT II U Bracket Combi AL - 160 x 60mm	9.53	6.97
300514	EVT II U Bracket Combi AL - 160 x 80mm	7.49	6.97
300515	EVT II U Bracket Combi AL - 160 x 100mm	6.19	6.97
300516	EVT II U Bracket Combi AL - 160 x 120mm	5.28	6.97
300517	EVT II U Bracket Combi AL - 160 x 140mm	4.62	6.97
300518	EVT II U Bracket Combi AL - 160 x 160mm	4.09	6.97
300519	EVT II U Bracket Combi AL - 160 x 180mm	3.67	6.90
300520	EVT II U Bracket Combi AL - 160 x 200mm	3.32	7.01
300521	EVT II U Bracket Combi AL - 160 x 220mm	3.05	7.01
300522	EVT II U Bracket Combi AL - 160 x 240mm	2.76	7.01
300523	EVT II U Bracket Combi AL - 160 x 260mm	2.55	7.08
300524	EVT II U Bracket Combi AL - 160 x 280mm	2.41	7.04
300525	EVT II U Bracket Combi AL - 160 x 300mm	2.23	7.04



Note to use with Floor Spanning Vertical Profiles only.

130530	EVT II Thermal pad 80 x 42mm
130531	EVT II Thermal pad 160 x 42mm



EVT U-Brackets – 3mm Stainless Steel (A2 & A4) FPH & SPH, slots for Concrete and Steel

Code	Description	Design Resistance (kN)	
		Vertical	Horizontal
300529	EVT II U Bracket A2 - 80 x 40mm	5.14	2.61
300530	EVT II U Bracket A2 - 80 x 60mm	3.07	2.61
300531	EVT II U Bracket A2 - 80 x 80mm	2.19	2.61
300532	EVT II U Bracket A2 - 80 x 100mm	1.69	2.59
300533	EVT II U Bracket A2 - 80 x 120mm	1.37	2.63
300534	EVT II U Bracket A2 - 80 x 140mm	1.15	2.61
300535	EVT II U Bracket A2 - 80 x 160mm	1.00	2.63
300536	EVT II U Bracket A2 - 80 x 180mm	0.87	2.63
300537	EVT II U Bracket A2 - 80 x 200mm	0.78	2.59
300538	EVT II U Bracket A2 - 80 x 220mm	0.71	2.59
300539	EVT II U Bracket A2 - 80 x 240mm	0.65	2.59
300540	EVT II U Bracket A2 - 80 x 260mm	0.59	2.59
300541	EVT II U Bracket A2 - 80 x 280mm	0.54	2.59
300542	EVT II U Bracket A2 - 80 x 300mm	0.50	2.59
300543	EVT II U Bracket A2 - 80 x 320mm	0.46	2.59
300546	EVT II U Bracket A2 - 160 x 40mm	17.90	5.43
300547	EVT II U Bracket A2 - 160 x 60mm	10.79	5.40
300548	EVT II U Bracket A2 - 160 x 80mm	7.66	5.40
300549	EVT II U Bracket A2 - 160 x 100mm	5.93	5.40
300550	EVT II U Bracket A2 - 160 x 120mm	4.85	5.40
300551	EVT II U Bracket A2 - 160 x 140mm	4.14	5.40
300552	EVT II U Bracket A2 - 160 x 160mm	3.56	5.40
300553	EVT II U Bracket A2 - 160 x 180mm	3.15	5.31
300554	EVT II U Bracket A2 - 160 x 200mm	2.82	5.24
300555	EVT II U Bracket A2 - 160 x 220mm	2.56	5.43
300556	EVT II U Bracket A2 - 160 x 240mm	2.34	5.18
300557	EVT II U Bracket A2 - 160 x 260mm	2.15	5.15
300558	EVT II U Bracket A2 - 160 x 280mm	1.96	5.47
300559	EVT II U Bracket A2 - 160 x 300mm	1.81	5.41
300560	EVT II U Bracket A2 - 160 x 320mm	1.73	5.41
300563	EVT II U Bracket Combi A2 - 160 x 40mm	13.22	6.97
300564	EVT II U Bracket Combi A2 - 160 x 60mm	9.53	6.97
300565	EVT II U Bracket Combi A2 - 160 x 80mm	7.49	6.97
300566	EVT II U Bracket Combi A2 - 160 x 100mm	6.19	6.97
300567	EVT II U Bracket Combi A2 - 160 x 120mm	5.28	6.97
300568	EVT II U Bracket Combi A2 - 160 x 140mm	4.62	6.97
300569	EVT II U Bracket Combi A2 - 160 x 160mm	4.09	6.97
300570	EVT II U Bracket Combi A2 - 160 x 180mm	3.67	6.90
300571	EVT II U Bracket Combi A2 - 160 x 200mm	3.32	7.01
300572	EVT II U Bracket Combi A2 - 160 x 220mm	3.05	7.01
300573	EVT II U Bracket Combi A2 - 160 x 240mm	2.76	7.01
300574	EVT II U Bracket Combi A2 - 160 x 260mm	2.55	7.08
300575	EVT II U Bracket Combi A2 - 160 x 280mm	2.41	7.04
300576	EVT II U Bracket Combi A2 - 160 x 300mm	2.23	7.04



Note to use with Floor Spanning Vertical Profiles only.

EVT II - Thermal Pads EVT and EVT II Brackets

Code	Description
130530	EVT II Thermal pad 80 x 42mm
130531	EVT II Thermal pad 160 x 42mm



System Aluminium Profiles

Note all profiles listed in 6M, but available in shorter lengths.

L Profiles

Code	Description
553168	L-Profile - 60 x 40 x 2mm (6.0m Length)
553197	L-Profile - 60 x 50 x 2mm (6.0m Length)
553355	L-Profile - 60 x 40 x 3mm (6.0m Length)



T Profiles

Code	Description
553170	T-Profile - 80 x 60 x 2mm (6.0m Length)
519043	T-Profile - 110 x 60 x 2mm (6.0m Length)
553196	T-Profile - 120 x 60 x 2mm (6.0m Length)
519056	T-Profile - 110 x 40 x 2mm (6.0m Length)
519058	T-Profile - 80 x 60 x 3mm (6.0m Length)



Structural Tophat / C-Channel Profiles

Code	Description
558325	Hat Profile FPH - 234 x 20 x 2/3mm (6.0m Length)
558326	Hat Profile SPH - 126 x 20 x 2/3mm (6.0m Length)
553900	C-Profile FPH - 176 x 27 x 2/3mm (6.0m Length)
553701	C-Profile SPH - 100 x 30 x 2/3mm (6.0m Length)
573702	C-Profile FPH - 180 x 30 x 2/3mm (3.0m Length) – A2 Stainless
573703	C-Profile SPH - 104 x 30 x 2/3mm (3.0m Length) – A2 Stainless
593702	C-Profile FPH - 180 x 30 x 2/3mm (3.0m Length) – A4 Stainless
593703	C-Profile SPH - 104 x 30 x 2/3mm (3.0m Length) – A4 Stainless

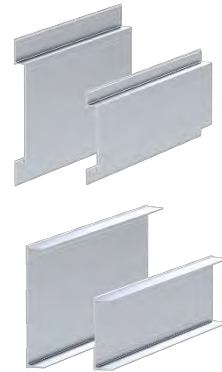

Floor Spanning Vertical Profiles

Code	Description
554309	Floorspan Profile – 40/38 x 60 x 2/3mm (6.0m Length)
554311	Floorspan T-Profile – 110/38 x 60 x 2/3mm (6.0m Length)

Note to use with EVT II U brackets only.

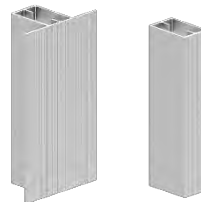

Tophats / Z Profiles for facade panels

Code	Description
558622	Hat Profile - 94 x 25 x 2mm (6.0m Length)
553200	Z-Profile - 45 x 25 x 30 x 2mm (6.0m Length)



Horizontal Rail Panel Systems

System Components - Forte L - Horizontal system, d = 30mm, t=2.3mm, w = 60mm

Code	Description
EVT Light - Horizontal Profile	
516374	Forte L Horizontal Profile (6.0m Length)
EVT Light - Panel Clasps	
516372	Forte L Adjustable/Fixed Clasp (M6)
516375	Forte L Adjustable/Sliding Clasp (M6)
516373	Forte L Sliding Clasp (M6)
539118	Forte L Adjustable/Fixed Clasp (M8)
539119	Forte L Adjustable/Sliding Clasp (M8)
539120	Forte L Sliding Clasp (M8)



System Components - Forte - Horizontal system, d = 32mm, t=3.8mm, w = 60mm

Code	Description
Forte - Horizontal Profile	
553206	Forte Horizontal Profile (6.0m Length)
Forte - Panel Clasps	
553207	Forte Adjustable/Fixed Clasp (M6)
553208	Forte Adjustable/Sliding Clasp (M6)
553209	Forte Sliding Clasp (M6)
553210	Forte Adjustable/Fixed Clasp (M8)
553211	Forte Adjustable/Sliding Clasp (M8)
553212	Forte Sliding Clasp (M8)



System Rails and Accessories

Stone ornate panels 40-80mm systemKERF

Code	Description
553281	Horizontal Upper / Lower Profile (6.0m Lengths)
553282	Horizontal Intermediate Profile (6.0m Lengths)
553283	Horizontal Upper / Lower Profile PPC 9005 (6.0m Length)
553284	Horizontal Intermediate Profile PPC 9005 (6.0m Length)



Bravo W

Code	Description
553227	W-Profile - 71 x 71 x 2.8mm (6.0m Length)
553228	W-Profile - 71 x 100 x 2.8mm (6.0m Length)
553229	W-Hanger 40 x 54 x 1.6mm (40mm Length)



Bravo H

Code	Description
553230	Bottom Horizontal Profile BH (6.0m Length)
553231	Top Horizontal Profile BH (6.0m Length)



Vario Lamella

Code	Description
553239	T-Profile VL - 99 x 61 x 2.2mm (6m Length)



Vario C20

Code	Description
553260	T-Profile VC20 130 x 85.7 x 2.2mm (6.0m Length)
553262	T-Profile VC20 130 x 83.2 x 2.2mm (6.0m Length)
553264	T-Profile VC20 130 x 70.2 x 2.2mm (6.0m Length)
553266	T-Profile VC20 130 x 61.2 x 2.2mm (6.0m Length)
553268	L-Profile VC20 66 x 61 x 2.2mm (6.0m Length)



Suitable ETA fixings subject to project approval

For fixing vertical profiles to wall brackets & horizontal rail to vertical rail. ETA approved

Code	Description
7380387300	JT4-4-4.8 x 19
7380508301	JT4-6-5.5 x 22



For fixing wall brackets to aluminium tophats. ETA approved

Code	Description
9900030064	JT4-6-5.5 x 22 A15
9900030234	JT4-6-5.5 x 30 A14



For fixing wall brackets to light steel sections 1.2 to 3.0mm steel. ETA approved

Code	Description
7380511301	JT3-3-6.3 x 38
3599611331	JT3-3-6.3 x 38 S16
7380582301	JT3-3-6.3 x 50
3599811331	JT3-3-6.3 x 50 S16



For fixing wall brackets to hot rolled steel sections 4.0 to 12.0mm steel. ETA approved

Code	Description
9900030386	JT3-12-5.5 x 40 S16
3593811311	JT3-12-5.5 X 67 S16



For fixing components i.e. soffit frameworks or cladding brackets to timber. ETA approved

Code	Description
3598811321	JT3-2-6.5 x 50 S16
9900100359	JT3-2-6.5 x 65 S16
3598011321	JT3-2-6.5 x 80 S16
9900030015	JT3-2-6.5 x 100 S16



For fixing wood parts to aluminium substructure i.e. wood sheets to aluminium for zinc cladding. ETA approved

Code	Description
7382160301	JT3-ST-2-6.0 x 35
7382125301	JT3-ST-2-6.0 x 60
7382107301	JT3-ST-2-6.0 x 80
7382101301	JT3-ST-2-6.0 x 100
7382102301	JT3-ST-2-6.0 x 120



For fixing brackets to concrete & block - cracked and non cracked concrete. ETA Option 1 approved

Code	Description
9900110057	JC6 KB 6 x 85/15 SW10
9900110059	JC6 KB 8 x 67/15 SW13
9900110060	JC6 KB 8 x 87/35 SW13



For fixing brackets to concrete - cracked and non cracked concrete. ETA Option 1 approved

Code	Description
9650005323	BA-E Plus-10/10/- Through Bolt A4



For fixing brackets to concrete & solid block. ETA approved

Code	Description
8581070650	SDF-KB 10V x 70-E

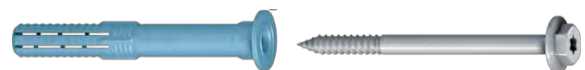

For fixing brackets to blockwork, brick, concrete & perforated brickwork. ETA approved

Code	Description
8513080620	SDF-KB 10H x 80-E
8513100620	SDF-KB 10H x 100-E



For fixing brackets to concrete & block - cracked and non cracked concrete. ETA Option 1 approved

Code	Description
9571000410	EJOT Multifix VSF 410ml
9570000400	EJOT Super Epoxy SE800 400ml
9900105600	M8 x 110 E A4 Ejot Stud C/w Nut & Washer
9900105599	M10 x 130 E A4 Ejot Stud C/w Nut & Washer



Section 5 – Factory Production Control

The RJ Facade Support Systems are manufactured in UK at UL audited sites. All associated fixings and other materials are externally sourced from RJ Façade Systems approved supplier chain. An initial factory production control audit has been carried out at the certified products manufacturing sites to assess the effectiveness of the following:

- Contract review – enquiries, quotations and orders
- Production planning and organisation
- Control of purchasing, including supplier approvals
- Control and storage of incoming materials and components
- Control of documentation related to the production, quality control/inspection, packaging and despatch
- Identification and traceability of certified products
- Ongoing production inspection, testing and records thereof
- Maintenance of production equipment
- Training Records of personnel
- Internal audit reports including non-conformances and corrective actions
- Customer complaint procedures
- Installation guide and processes
- Non-conforming products
- Labelling of products

UL witnessed the production and quality processes at each manufacturing site and storage location in the UK. It can be confirmed that the procedures and controls were carried out as specified and documented, and were in line with the UL Mark certification scheme requirements. The completed products are dispatched to RJ Facade Systems in Bathgate where they are stored prior to final delivery to the clients. All sites related to this certificate will be subjected to further onsite annual audits to ensure ongoing compliance and effectiveness of their quality control systems.

Section 6 – Design documentation review of the certified products

A review of the certified products documentation was conducted in order to help demonstrate compliance with the appropriate sections of the UL Mark Scheme and applicable NHBC 2019 Standard requirements. At least the following requirements were evaluated in the review and were found to show evidence of compliance.

3.1 Loads and movements

The range of cladding support systems, allow movement without causing damage or deformation, Loads are all calculated in accordance with BS EN 1991-1-1 and BS EN 1991-1-4 using the wind load calculator to Eurocodes. Recommended fastening spaces are based on calculations in accordance to Eurocode EN 1991-1-4.

3.2 Support and Fixings

The RJ Facade Support Systems have demonstrated that they can be securely fixed with suitably durable fixings to ensure adequate in-service performance. A series of load testing on brackets was witnessed by UL this demonstrated that the fixings could accommodate the specified design wind loads. Pull out testing is also carried out onsite by RJ Facades on request of their clients. European Technical Approvals are available for the range of Ejot fixings used in the support systems.

3.3 Durability

The product provides satisfactory durability with a high durability rating from Eurocode EN1999.1.1.2007 (Design of aluminium structures). The system has been designed to avoid the need for disproportionate work when repairing or replacing individual cladding components. Corrosion resistant fixings are used, and bimetallic corrosion has been considered.

3.5 Installation

Installation is to be supplied by others, detailed site-specific risk assessments and method statements are produced by site contractors. RJ Facade Systems supply a summary calculation report for all projects. Onsite product training is made available on request.

- 3.7 Electrical continuity and earth bonding
Method statements for the installation of the RJ Façade Support Systems cladding system specify that the electrical continuity and earth bonding is to be managed by separate contactors onsite during installation.
- 3.8 Behaviour in relation to fire
The aluminium brackets, rails and associated rail-to-bracket fixings are non-combustible and, therefore, could be regarded as having a Class 0 or 'low risk' surface in relation to the current National Building Regulations at the time of writing. To limit the risk of fire spread between floors in buildings subject to national Building Regulations, cavity barriers must be incorporated in the cavity behind the systems, as required under these Regulations (for example, intumescent cavity barriers — specific types not covered by this Certificate — or overhanging incombustible breaks at each floor level), but these should not block essential ventilation pathways. Guidance on cavity barriers can be found in BRE Report BR 135 :2013, but these are outside the scope of this Certificate.
- 3.14 Drainage and Ventilation
The Cladding Support System has been designed so that drainage and ventilation is considered and managed effectively. RJ Facades can make details available on request.
- 3.11 Handling and storage
An onsite assessment of the manufacturer confirmed that materials, products and systems are protected and stored in a satisfactory manner to prevent damage, distortion and uneven weathering. The UK warehouse also demonstrated that all products are kept in easily identifiable locations and are stored in a way to prevent any damage or possible degradation.

Section 7 – Comments on the certified products contribution to The Building Regulations

A top level review of the key related requirements from The Building Regulations 2010 (England and Wales) was conducted based on the information declared by RJ Façade Systems and the data provided for the documentation review. The following comments have been made on whether the certified product can contribute to the Building Regulations requirements.

The Building Regulations 2010 (England and Wales)

Requirement	Comment/s
A.1 Loading	The calculations and test data provided give confidence that this regulation is contributed towards by the products tested and certified.
B4 (1) External fire spread	The aluminium brackets, rails and associated rail-to-bracket fixings are non-combustible and, therefore, could be regarded as having a Class 0 or 'low risk' surface in relation to the current National Building Regulations at the time of writing. Fire certification/performance is outside the scope of this Certificate
7. Materials and workmanship	The evidence of method statements, internal documentation and staff training provided gives confidence that this regulation is contributed towards by the product certified.

Section 8 – Product installation

General

This product must be installed in accordance with RJ Façade Systems recommendations and the any details specified in this certificate. RJ Façade Systems have specified that product Installers can be trained and approved by them directly on request. Any trained and approved installers will be issued with an appropriate in-house certificates/training evidence.

Product delivery

The products are delivered to the UK RJ warehouse on banded on wooden pallets with suitable packaging. Each delivery is labelled with details including; order number, location, product name, type, size, quantity and weight.

Site survey

RJ Façade Systems have specified that prior to installation of the Cladding Support System; a pre-installation survey of the property has to be carried out by the client or a suitable engineer to determine whether the site is suitable for product installation, and if any repairs are required to the building wall.

Section 9 – Supporting test documentation

General

All brackets and fixing configurations have FEA modelling carried out to establish max wind or pull-out loads. Actual Load testing of the cladding support systems brackets and fixings was carried out by RJ Fixings at their UK location and was witnessed by UL. The products were tested as detailed below.

Testing witness date

The testing was witnessed on the 15th March 2022 and was completed by the 30th March 2022.

Test witness laboratory

UL (UK) International Ltd, Telford, Shropshire TF7 4QH

Test rig and equipment

In order to validate the FEA models, the brackets and hangers were subjected to physical load testing.

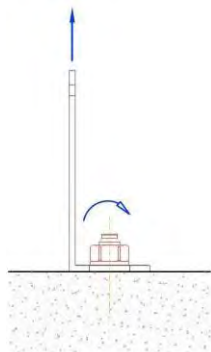

Wind loading configuration

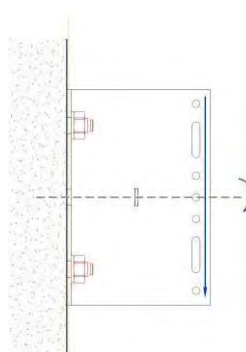

Dead loading configuration

These tests were used to simulate both the wind and dead loads. For each bracket range and variety, the shortest, longest and middle length brackets were tested both in wind load and dead load configuration. For each individual bracket, 3 wind load and 3 dead load tests were carried out. Over the entire range, this led to over 100 tests being carried out.

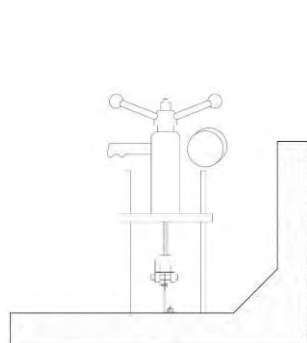

Wind loading test set up procedure

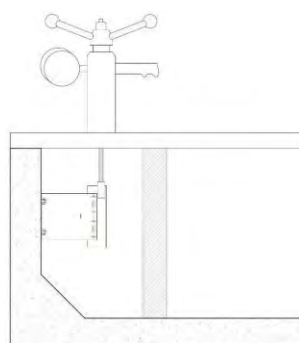

Dead loading test set up procedure

The method for each individual test was kept the same, the bracket/hanger was loaded to at least the value calculated from the FEA software. Calibrated dial test indicators were used in order to measure the deflection as a screw jack applied a gradually increasing load. The dial indicator was set to zero when the bracket was in its original, unloaded state. The maximum load was held for one minute, and then released back to zero by releasing the screw jack. The dial test indicator was then observed in order to determine whether the bracket had returned to its original unloaded position.

Conclusion

The FEA model created is an accurate representation of what the brackets experience in service, and the behaviour of the bracket as modelled in the software closely resembled the reality during tests.

The physical testing supports the FEA model was well calibrated, and the results are acceptable. Therefore, the results calculated from the FEA software can be taken as the design loads for each range.

Section 10 – Certification conditions

This UL Mark Certificate:

1. Covers the product/system that is named and described on the front page only.
2. Should be read in conjunction with the UL Mark – Performance of Curtain Walling and Rainscreen Cladding certification scheme document.
3. Is granted to the company listed front page only.
4. Is valid within the UK only.
5. Will remain valid for the period listed on the front page provided that the product and the manufacturer comply with the UL Mark requirements.

Please check the validity and issue level of this certificate with UL (UK) International, or check the list of certified products online via www.UL.com. UL is not responsible for any mistakes, complaints, legal issues or liability regarding the incorrect manufacture or installation of any UL Mark certified products. This is not fire certification, evidence of fire performance should be obtained directly from the company certified. For more details the UL Mark certification terms and conditions and the UL Mark Scheme document should be read in conjunction with this certificate.