



Ventilated Facade Systems for Cladding Materials

Technical brochure

System Profiles & Structural Support Profiles

L, T, Floorspan Profiles

Structural C & Tophat Profiles

Zed & Hat Profiles

EVT II - L Profiles, Aluminium

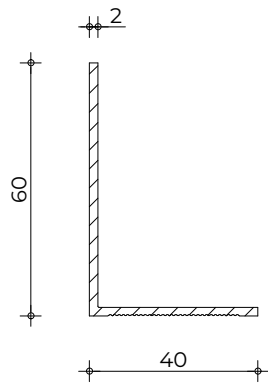

L-Profile - 60x40x2

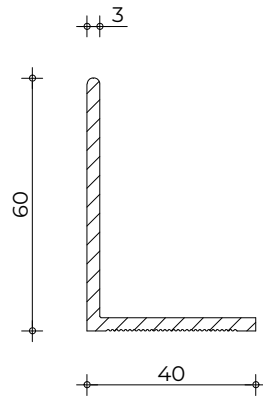

L-Profile - 60x40x3

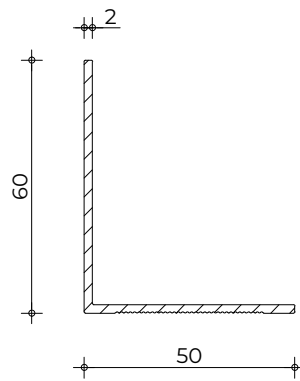

L-Profile - 60x50x2

| Item | Material |
|-----------|--------------------------|
| L-Profile | Aluminum - EN AW 6063 T6 |

EVT II - T Profiles, Aluminium

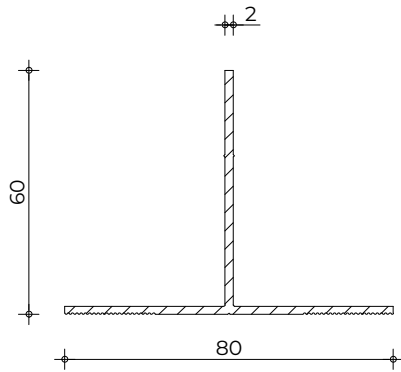

T-Profile - 80x60x2

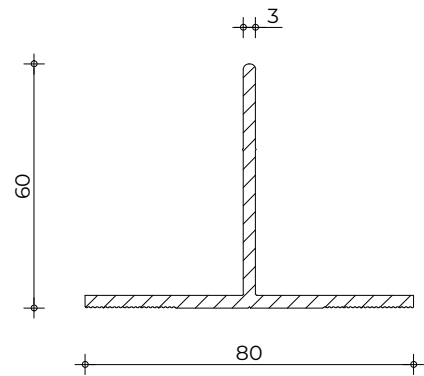

T-Profile - 80x60x3

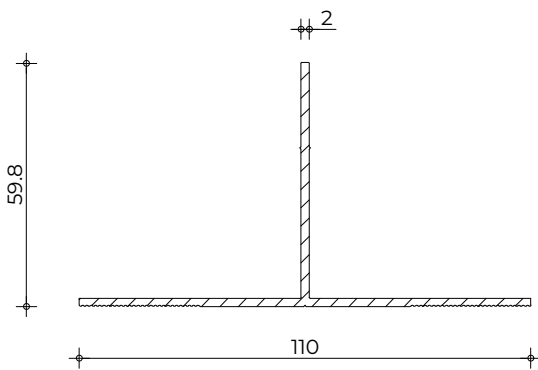

T-Profile - 110x60x2

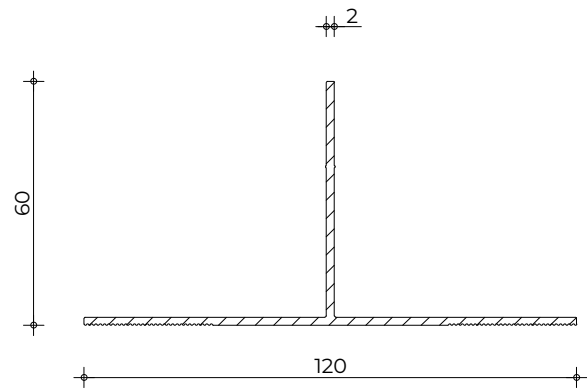

T-Profile - 120x60x2

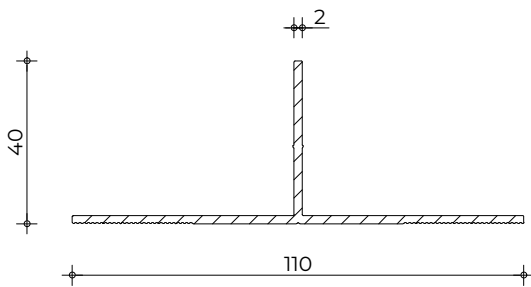

T-Profile - 110x40x2

| Item | Material |
|-----------|--------------------------|
| T-Profile | Aluminum - EN AW 6063 T6 |

EVT II - Floorspan Profiles, Aluminium

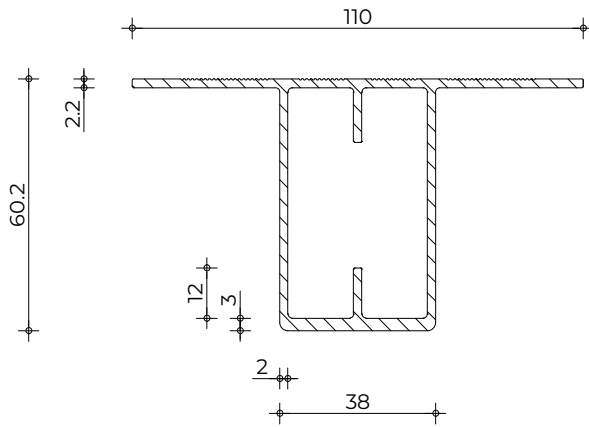

Floorspan T-Profile - 110/38 x 60 x 2/3

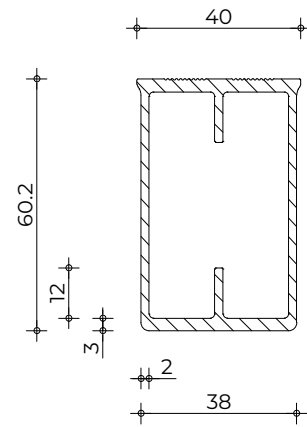

Floorspan Profile - 40/38 x 60 x 2/3

| Item | Material |
|--------------|--------------------------|
| Box Sections | Aluminum - EN AW 6063 T6 |

EVT II - Structural C Channels, Aluminium

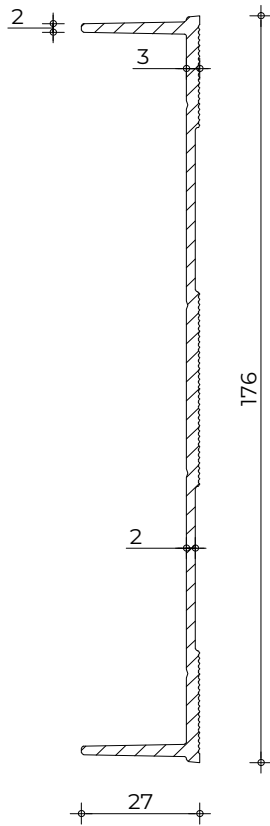

C-channel 176x27

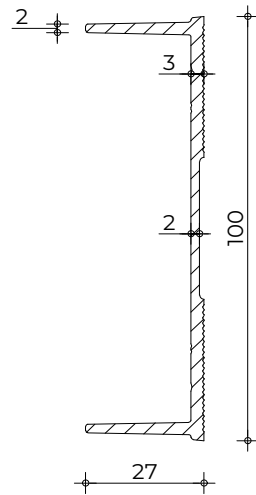

C-channel 100x27

| Item | Material |
|------------|--------------------------|
| C-Profiles | Aluminum - EN AW 6063 T6 |

EVT II - Structural C Channels, Stainless Steel

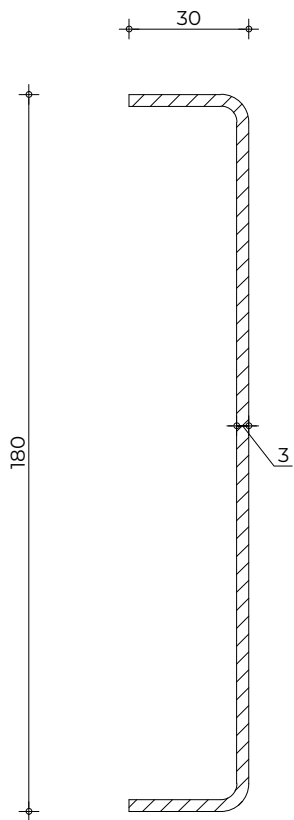

FPH C-Channel 180x30

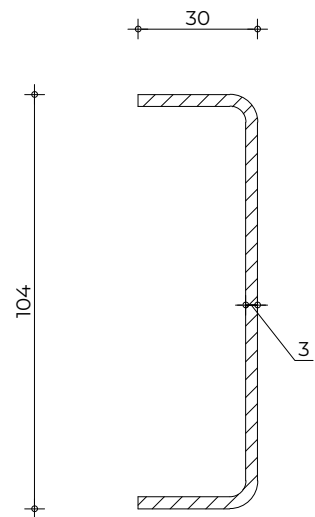

SPH Top Hat 104x30

| Item | Material |
|-----------|--------------------------------|
| C-Channel | St. steel 1.4301/1.4401/1.4404 |

EVT II - Structural Top Hat Profiles, Aluminium

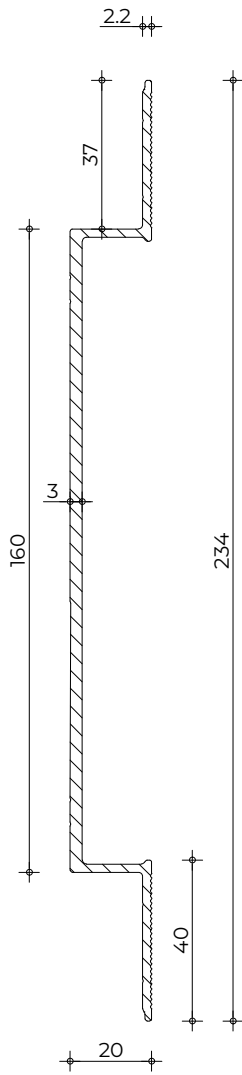

FPH Top Hat 234x20x160

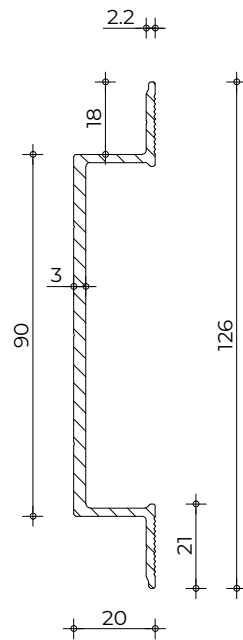

SPH Top Hat 126x20x90

| Item | Material |
|---------|--------------------------|
| Top Hat | Aluminum - EN AW 6063 T6 |

EVT II - Zed and Hat Profile, Aluminium

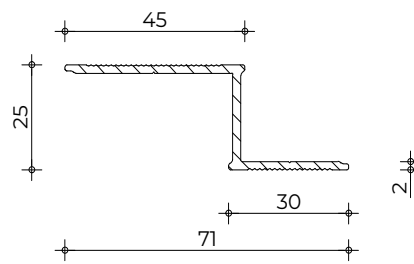

Zed Profile - 45x25x30x2

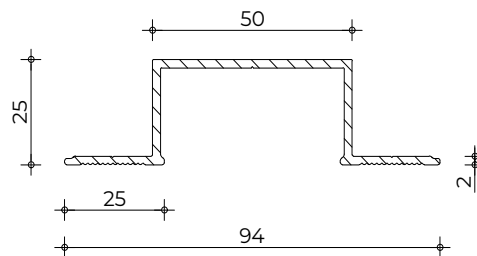

Hat Profile - 94x25x2

| Item | Material |
|-------------|--------------------------|
| Hat Profile | Aluminum - EN AW 6063 T6 |
| Zed Profile | Aluminum - EN AW 6063 T6 |

Standards & liability

Standards

General

EN 12020 (1÷2) - Aluminium and aluminium alloys - Extruded precision profiles in alloys EN AW-6060 and EN AW-6063

EN 755 (1÷9)- Aluminium and aluminium alloys - Extruded rod/bar, tube and profiles

EN 573 (1÷3) - Aluminium and aluminium alloys - Chemical composition and form of wrought products

EN 15088 - Aluminium and aluminium alloys - Structural products for construction works - Technical conditions for inspection and delivery

EN 1990 Eurocode - Basis of structural design

EN 1991 Eurocode 1 - Actions on structures

EN 1998 Eurocode 8 - Design of structures for earthquake resistance

EN 1999 Eurocode 9 - Design of aluminium structures

Ventilated façade systems

ETAG 034, part 1 - Kits for external wall claddings, Part I: Ventilated cladding kits comprising cladding components and associated fixings

ETAG 034, part 2 - Kits for external wall claddings, Part II: Cladding kits comprising cladding components, associated fixings, subframe and possible insulation layer

CWCT Standard for Systemized Building Envelopes

EN 13830 - Curtain walling - Product standard

EN ISO 6946 - Building components and building elements - Thermal resistance and thermal transmittance - Calculation method

EN ISO 10211 - Thermal bridges in building construction - Heat flows and surface temperatures - Detailed calculations EN

ISO 14683 - Thermal bridges in building construction - Linear thermal transmittance - Simplified methods and default values

EN 13116 - Curtain walling - Resistance to wind load - Performance requirements

EN 12179 - Curtain walling - Resistance to wind load - Test method

EN 14019 - Curtain Walling - Impact resistance - Performance requirements

EN ISO 10140 - Acoustics - Laboratory measurement of sound insulation of building elements

EN 20140 - Acoustics - Measurement of sound insulation in buildings and of building elements

EN ISO 717-1 - Acoustics - Rating of sound insulation in buildings and of building elements - Part 1: Airborne sound insulation

Liability

The stated data and calculating methods are provided by RJ Facades as a guideline only.

The information given in this catalogue does not substitute all applicable regulations – Eurocodes, harmonized European standard, national or regional building codes.

The specific conditions and technical details of every particular project have to be taken into consideration.

The right choice of all elements as well as any special requirements regarding stability of the structure must always be considered by the structural/façade engineer, responsible for the project.

The solution presented in these pages are indicative and cannot cover all possible project cases. Because of that every single project has to be evaluated by the structural/façade engineer in charge taking into consideration the specific features, such as climate conditions, location, orientation, etc.

RJ Facades is not liable for any calculation and conclusions made on the basis of the stated information. All calculations and specifications must be estimated, endorsed and guaranteed by architect, engineer, professional or legal entity authorized by law for such activities.

rjfacades.com

